

U-Series – Handwheel / Installation Manual

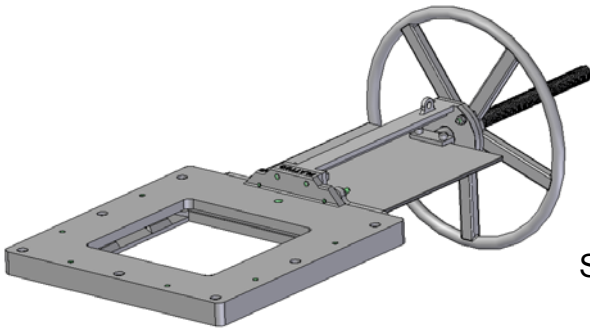

Design Code: _____

Stock Number: _____

Serial Number(s): _____



When your process is critical, when conditions are demanding,
When your valve has to work, it has to be a **Plattco Valve**.

Plattco.com

e-mail: info@Plattco.com

international calls: 1.518.563.4640

USA/domestic calls: 1.800.352.1731

7 White Street, Plattsburgh, NY USA 12901

Table of Contents

Description	Page
History of Plattco	1
Sales Contact List	2
Introduction	3
Packaging / Storage	4
Safety Precautions	5
Installation	6
Maintenance	7 – 8
Troubleshooting	9
Standard Paint Specification	10
Gate Accessories and Options	11
Ordering Replacement Parts	12
	APPENDIX
Start-up procedure	A
Installing shaft seals	B

History of Plattco

Page 1

Plattco Corporation Over 100 Years of Innovation and Excellence

Plattco specializes in the design and manufacture of Double Flap Airlock® Valves and associated Multi-Purpose Slide Gates to solve solid material handling problems in a wide variety of industrial applications.

We began as a gray iron foundry in 1897 producing drainage castings, stock valves and other machined castings for the paper, mining, and other regional industries. Always a leader, Plattco became the first licensee for “white irons” (Ni-Hard, Hi-Chrome, Ni-Resist) patented by International Nickel in the 1930’s.

Our customers have always looked to us for solutions to their most difficult dry material handling issues. This problem-solving role led us to invent the first Double Flap Airlock® Valves forty years ago to eliminate leakage with sintering and pelletizing in the mining industry, and for the handling of cement clinker.

Since then, Plattco has engineered thousands of solutions, in dozens of industries, throughout the world. We have established an unmatched reputation for correcting process design problems in applications that involve high temperature, high pressure, and/or abrasive/corrosive materials.

Plattco is an integrated manufacturer, with our own engineering, pattern shop, foundry, and machine shop in Plattsburgh New York. The company owns several U.S. and International patents and is the premier innovator in the solid materials handling valve business.

Plattco is employee owned. Every employee is a stockholder and, thus, every employee has a direct interest in ensuring that our customers are delighted with our valves and continue to consider us the best company in our industry.

We are proud of our history and mindful of our responsibility to provide the very best solution to every material handling application we undertake.

Sales Contact List

Page 2

Contacts	Titles
John O'Brien Phone: 518-563-4640 ext. 137 E-mail: jobrien@plattco.com	Regional Sales Manager
Robert Bourgeois Phone: 518-563-4640 ext. 104 E-mail: bbourgeois@plattco.com	Strategic Account Manager
Dianne Lynch Phone: 518-563-4640 ext. 160 E-mail: dlynch@plattco.com	Customer Service / Inside Sales
Roxanne Coleman Phone: 518-563-4640 ext. 125 E-mail: rcoleman@plattco.com	Customer Service / Parts Sales

Introduction

Page 3

This manual contains instruction on how to assemble, install, operate, and service the Plattco Slidegate.

- Plattco Slidegates are designed for ease of installation and maintenance, and to give long, trouble free service.
- The gates will operate automatically with little maintenance required.

Assembly

- Gates are normally shipped completely assembled and ready to install at the job site.
- Gates will be shipped disassembled only when transit conditions prevent the shipment of complete units.
- When shipped disassembled special instruction for assembly of the unit will be provided.
- Gates should be inspected when received to make sure no damage occurred during transit.

Packaging / Storage

Page 4

Packaging

All flanges and unpainted surfaces of the gate s are coated with a light weight oil to help prevent corrosion. The unit is then wrapped in heavy plastic. Finally, it is placed and secured in a Plattco shipping container, along with the appropriate paperwork.

Storage

Plattco recommends the unit be stored **un-stacked and upright** in a dry place until needed.

Safety Precautions

Page 5

Do not service Plattco Slidegates until:

1. The gate has been locked out and tagged out following proper lock-out / tag-out procedures.



2. All power supplies have been disconnected.
3. All electrical current has been turned off.
4. Pressure above and below the gate has been reduced to atmospheric.
5. Material above the gate has been removed or isolated.

Keep hands, feet, loose clothing, other equipment, or tools away from moving parts until the above steps have been taken to prevent possibility of bodily injury.

Failure to heed these warnings could result in an accident causing damage to equipment and / or severe personal injury.



Installation

Page 6

Manually operated Plattco Slide gates are shipped ready for installation (unless otherwise noted). If disassembled, Plattco will furnish any mounting procedures required.

Plattco gates are mated to above and below equipment with flange gaskets and bolts.

It is recommended that the duct work, piping, or feed opening directly above the gate be **not** larger than the gate inlet. If it is larger this may cause premature erosion of the gate housing and/or seat and will void all warranties.

During installation make sure the gate is oriented in the correct position. See illustration below.

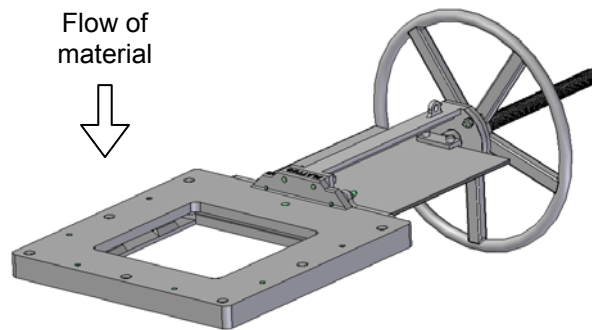

Maintenance

Page 7

The access covers on the Plattco Slidegates are designed to facilitate maintenance of the gate, seals, and other internal parts. The following is a procedure for removing and reinstalling the gate and seals.

See Safety Precautions on Page 5 before performing any maintenance to the gates!

Removing Gate and Seals

1. Retract stem / pull block
2. Remove pull block fasteners from gate
3. Remove yoke mounting fasteners
4. Remove yoke assembly w/ handwheel attached
5. Remove seal retainer fasteners
6. Remove gate
7. Remove seal retainer
8. Remove old seals

Reinstalling Gate and Seals

1. Clean and replace gate.
2. Clean interior of housing thoroughly.
3. Install gate
4. Install new seals
NOTE: install one seal at a time making sure to stagger seal ends
5. Position seal retainer
6. Install seal retainer fasteners DO NOT TIGHTEN
7. Mount yoke assembly w/ air cylinder attached to housing
8. Mount pull block to gate
9. Tighten seal retainer fasteners evenly until resistance is felt
10. Manually cycle gate to seat seals
11. Again tighten seal retainer fasteners evenly until resistance is felt

Before starting or operating Plattco gates it is important that all fasteners be checked for tightness.

Maintenance

Page 8

Lubrication

Always use a good grade bearing grease or high temperature grease in hot applications, equal to the following:

Jet Lube AP-5

Lubrication Chart

Component	Handwheel
Lubricant	Jet Lube AP-5 HT or equal
Specifications	NLG 1 Grade 2
Initial Fill Qty.	N/A
Frequency	Once per month
Quantity	2 ml
Total Qty Required per 1 year of operation	24 ml

Troubleshooting

Page 9

Review this chart to find do-it-yourself solutions for minor performance problems. Any service needed other than those described in this manual should be performed by an authorized Plattco service representative.

PROBLEM	POSSIBLE CAUSE	POSSIBLE SOLUTION
Seal failure	1 Loose seal retainer	1 Take up
	2 Seal break down	2 Replace seals
	3 Internal pressure too high	3 Contact Plattco
	4 Misapplied	4 Contact Plattco
Gate not sealing properly	1 Moist sticky material	1 Sharp edge gate (contact Plattco)
	2 Worn gate	2 Replace as needed
	3 Not installed properly	3 Refer to page 7 of this manual

FOR TECHNICAL SUPPORT AND CUSTOMER SERVICE PLEASE CALL:

1-800-352-1731

(518) 563-4640

Standard Paint Specification

Page 10

Supplier: Westfield Coatings

Product: Heat resistant aluminum 3 9-9SP3358

Type: Modified alkyd silicone

Viscosity: @ 75 degrees F 38-42 "z3

Sheen: Bright

Weight/gal: 8.10 lbs.

Solids/weight: 27.28 lbs.

Flash Point: 35 degrees F

For use on: Metal

Surface Prep: Clean and dry

Gate Accessories and Options

Page 11

Accessory / Option	Function
Drives	Air, hydraulic, handwheel, and chainwheel
Dutchmen	Spool pieces mounted between valves to increase throughput.
Expansion joints	Connects valve assemblies with ductwork to minimize the effects of temperature expansion, vibrations, and torque.
Export crating	Secure crating to meet overseas transport requirements.
Mechanical limit switches	Senses the opening and closing of valves by means of mechanical contact.
NEMA enclosures	Dust tight, water tight, explosion proof enclosures available to suit customer requirements.
Proximity switches	Senses the opening and closing of valves by means of a non-contact magnetic field.
Safety guards	OSHA approved for covering moving parts, mechanical linkages, air cylinders, and gates.

FOR TECHNICAL SUPPORT AND CUSTOMER SERVICE PLEASE CALL:

1-800-352-1731

(518) 563-4640

Ordering Replacement Parts

Page 12

When ordering genuine Plattco replacement parts please have any, or all, of the following information available to insure the correct parts are ordered for your specific gate. This will also help in expediting your order.

- Part stock number (part number) – located on bill of materials supplied with gate when purchased.
- Serial number – located on the nameplate attached to the side of each gate.
- Bill of materials – supplied with gate when purchased.
- Assembly drawing – supplied with gate when purchased.
- Model number – located on the nameplate, assembly drawing, and bill of materials.
- Original purchase order, contract number, or Plattco order number.

Returned Goods Policy

If Plattco Corporation has approved and issued a RGR authorization number to the original purchaser, parts and/or gates may be returned by the purchaser for credit within 90 days of Plattco Corporation's shipment. As long as the parts and/or gates were not custom designed, and they are returned in their original condition and packaging. Once returned and accepted, a credit will be issued for the original invoice price, less 25% restocking charge on complete gate assemblies and less 40% restocking charge on parts.

APPENDIX

Start-up Procedure

APPENDIX A

Gates with Standard Packing Seals

I. At Start-Up

- a. Inspect and adjust air supply pressure regulator to maintain optimum 80 psig pressure.
- b. Mount the FRL (Filter/Regulator/Lubricator assembly), if required, in a position above the valves as described on page 5 of this installation manual.
- c. Make sure all fasteners are tight.
- d. Make sure all lubrication points are adequately greased.
- e. If seal leakage is evident, take up on seal retainer. The first day is critical for proper shaft seal break-in.
- f. Integrate a routine Plattco gate maintenance schedule with plant maintenance.

II. After Start-Up

- a. Weekly
 - i. Check lubricator oil level (if applicable).
 - ii. Lubricate grease fittings.
- b. Monthly
 - i. Check fasteners for tightness.
 - ii. Check cylinders for leakage.

Installing Shaft Seals

APPENDIX B

Standard Packing Shaft Seals

The importance of packing the valve correctly cannot be overemphasized. Many valve shaft seal leakage issues are due to incorrect packing installation.

1. Remove all existing packing.
2. Clean packing pocket and shaft thoroughly. Examine all parts for wear or scoring. Any parts with excessive wear should be replaced.
3. Be sure to use the correct size packing. If you are unsure of what size packing to use, contact Plattco Corporation.
4. If packing is not pre-cut, cut into separate rings – do not wind packing into the packing pocket. Packing rings should be cut with a skive joint, see illustration below.

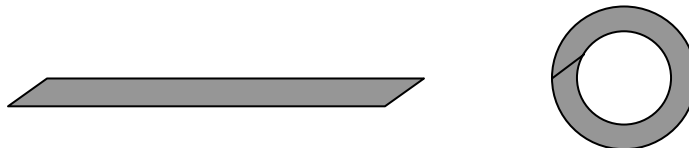

Cut and test the first ring for fit – this can later be used as a template for additional rings. **HINT:** To cut packing that is soft, or has a tendency to fray; apply a small piece of tape where the cut is to be made.

5. Install packing one ring at a time. Skive joints must be staggered and be sure all packing is clean and has not picked up any dirt during handling.
6. Set packing. Slide a piece of pipe, or similar object, over the shaft and hit packing together.
7. Install seal retainers. Tighten seal retainer screws until to the point where heavy resistance to tightening is felt. During this time, manually open and close the valve to determine ease of opening. Do not tighten seal retainer screws to the point the valve won't open and close freely.
8. After the valve has operated a day or so tighten the seal retainer screws slightly. If leakage is occurring, tighten screws until leakage stops.
9. Safety wire all seal retainer screws after adjusting.

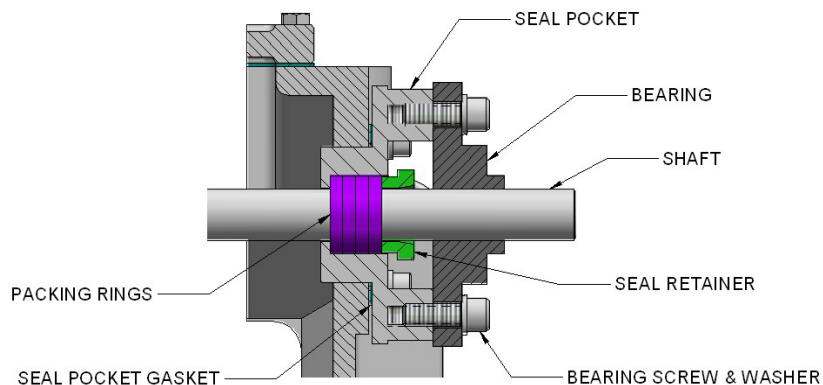

Typical valve seal section