

Plattco S8-Series Double Flap Airlock® Valve

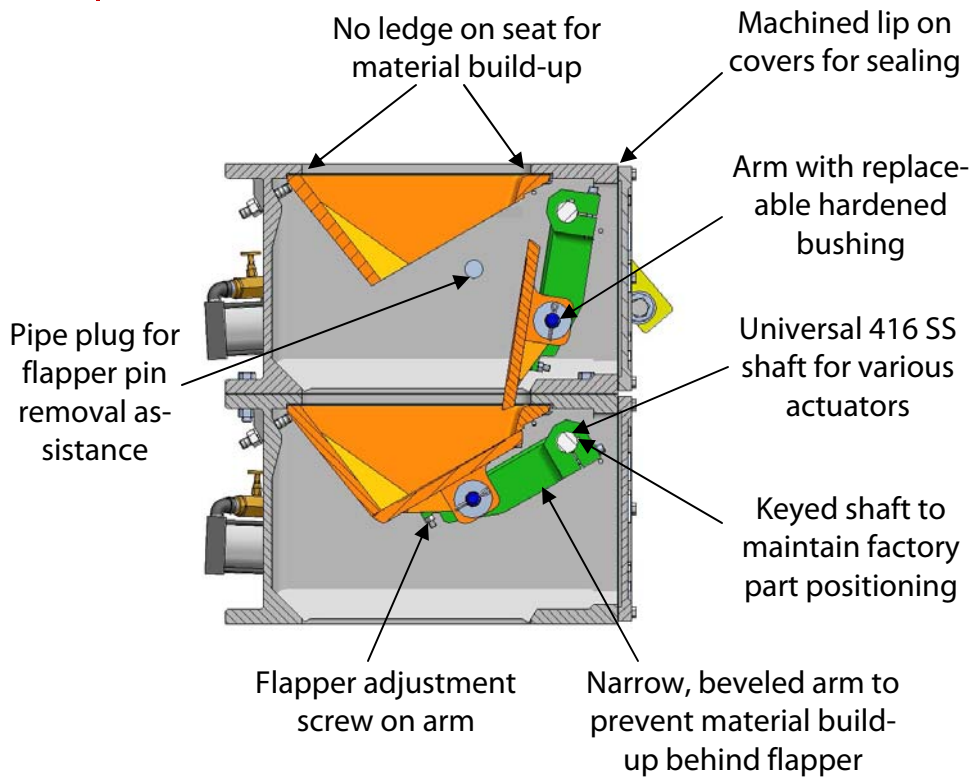

The S8-Series features & benefits:

- Temperatures up to 1800°F.
- Pressures up to 15 psi differential.
- All cast construction for consistency and corrosion resistance.
- Proprietary alloys for durability and wear resistance.
- Seats and flappers precision machined to eliminate air leakage.
- Seats and flappers can be reground to “like new” condition and performance.
- Housing is not part of the seal allowing it to last for decades.
- Proprietary design eliminates bridging, jamming, and material build-up.
- Reduces maintenance and operating costs.
- Optimizes system performance.

The Plattco benefit:

- Experience
 - 50 years of valve and gate expertise, 75 years of metallurgical and manufacturing experience.
 - Plattco is the industry standard.
- Proven reliability
 - Field proven quality—30 year old valves still in operation.
- Dedication
 - Employee owned—dedicated and experienced sales, engineering, and manufacturing teams all under one roof.
 - Each application is custom engineered.
 - After sales support—experienced parts and customer service personnel.
 - Highly trained and experienced field service / technical services department.
 - Quick turnaround for custom applications—foundry and machine shop are both on site.

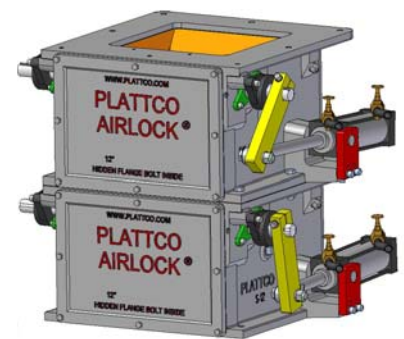

Plattco S8-1222 shown